



SprayMaster 9400

INSTRUCTION AND OPERATION MANUAL



AQUEOUS PARTS CLEANERS

**Fountain Industries, LLC.
922 East 14th St.
Albert Lea, MN 56007**

**Phone: 800-328-3594
507-373-2351**

Fax: 507-373-7404

Email: CS@ftnllc.com

www.FOUNTAININDUSTRIES.com

I. PRECAUTIONS/DANGERS

Read this entire manual before attempting to install your SprayMaster jet washer. You will be less likely to make mistakes if you have a grasp of the “whole” picture.

DANGER

1. Your machine uses HIGH VOLTAGE electricity. Obtain the services of a qualified electrician for all electric work.
2. Do not use any petroleum base chemical or solvent, or any flammable products in your jet washer.
3. The heating element (s) will be ruined and the pump/motor may get damaged if they are turned on when the holding tank is empty or has a low water level. Check the water level at least daily.
4. Cleaning will be poor and the heating element (s) and pump/motor may get damaged if the machine is not cleaned according to instructions.
5. Your jet washer is made with mild steel and will rust unless you use the correct detergent and follow the correct start-up procedure. If you are not using a Fountain Industries detergent, make sure the brand you are using is safe on mild steel and has an adequate concentration of rust inhibitors. When installing the unit, don't fill the tank with water unless you have the time needed to heat the water to 150°-170°F, add the detergent, and run the wash cycle for at least two (2) hours to cat the steel with rust inhibitor. Again, read this entire manual before starting the installation so that you know what is involved. (see “chemical Selection”)
6. Since laws and regulations are forever changing, and since they often vary region to region, the remarks in this section should only be construed as a general guideline. It is your responsibility to research, understand, and follow the exact environmental regulations of your region.

Protect your environment and protect your business from fines by handling your dirty cleaning solution according to federal, state, and local codes. According to federal regulations, which states have to adopt as minimum standards, the dirty

cleaning solutions in a spray washer generally are not “hazardous wastes”. To be considered a hazardous waste a hazardous waste by the U.S. Government, the solution has to have one or more of the following (4) characteristics:

- a. **IGNITABILITY** – A solid waste is a hazardous waste if it is a liquid and a representative sample and has a flashpoint less than 140°F.
- b. **CORROSIVITY** – A solid waste is a hazardous waste is it is an aqueous solution and a representative sample, and if it has a pH less than or equal to 2 or grater than or equal to 12.5
- c. **REACTIVITY** – A solid waste is a hazardous waste if a representative sample reacts violently with water or releases cyanide or hydrogen sulfide when exposed to low pH solutions.
- d. **EP TOXICITY** – A solid waste is a hazardous waste if a representative sample leaches heavy metals in concentrations greater than 100 times primary drinking water standard concentrations.

The two characteristics that you have to be most concerned about are **CORROSIVITY** and **EP TOXICITY**. Ask your detergent supplier if the pH of your solution is greater than 12.5 and if so, how it can be neutralized with acid. To check for EP Toxicity, you would need to have a sample tested by a laboratory.

Assuming that your solution is not hazardous, or that with minor treatment (e.g., adding acid) the solution can be made non-hazardous, the EPA does not require special storage, documentation, transportation, and processing. Since your solution will have oils, however, you will probably not be able to dump the solution in the sewerage line (call your sewage treatment facility) and you certainly can't dump the solution on the ground or in a storm drain.

Given the above information, the best approach is to clean-up or filter the solution so that the water content can be continually re-used. A dirty solution separates into three (3) layers – oils rise to the top, sludge sits on the tank bottom, and the water layer is in the middle. The surface oils, which are skimmed off with the 61530 skimmer, can generally be stored with your other waste oils. The sludge, most of which is trapped in the “Purifier” section of the tank, is occasionally removed and stored as “hazardous” waste to be conservative.

II. CONTROLS/OPERATION

Your jet washer automatically cleans parts by spraying them with a hot, detergent and water solution that is recirculated. The operator loads parts into the basket, shuts the door (lid), and starts the cleaning cycle. During the cleaning cycle, the parts basket rotates through spray curtains, which are created by, spray nozzles located above, below, and outside the turntable. The force of the spray jets, in combination with the heat and the chemical action of the detergent will remove contaminants within minutes. Generally, any contaminant that can be removed will be removed within 15 minutes.

➤ THE HEATING SYSTEM/WATER LEVEL

The wash solution is recirculated from a holding tank, which forms the base of the jet washer. The capacity of the tank is 65 gallons. The correct water depth is 11".

The holding tank is heated with electric heating elements that are controlled by a toggle switch adjustable thermostat. The thermostat is located on the right side, close to the floor. The black adjustment knob is mounted next to the heating element cover.

Most customers set the temperature between 140° and 160°F. Below 140°F, many detergents will foam (consult your detergent supplier.) Above 180°F, your pump may cavitate, resulting in lower pressure and poor cleaning results.

To turn the heating elements on and off, the Jet Washer has the standard toggle switch. Allow 3-1/2 hours for a 100° - 110°F temperature rise.

➤ THE WASH CYCLE/FILTRATION

When the door is closed, the 0-60 minute “WASH” timer starts the wash cycle as soon as it is turned. Generally, a 20-minute wash cycle is more than sufficient to remove the contaminants.

During the wash cycle, the solution hits the parts and then returns to the tank via a removable filter basket located beneath the turntable.

A limit switch assures that the wash pump can only operate when the door is closed. The limit switch is for safety and is not to be used to purposely stop the cycle. Wait until the wash timer reaches zero before opening the door.

➤ OIL SKIMMER

The skimmer has an 11 1/2” disc that is partially submerged. The floating oils adhere to the disc and subsequently get wiped off and run into a bucket.

The skimmer is controlled by a push button switch on the control panel. The skimmer timer allows the skimmer to operate for 45 minutes. DO NOT operate the skimmer while the machine is washing parts

II. INSTALLATION

DANGER This machine utilizes HIGH VOLTAGE. Have a certified electrician do all electrical work. Always disconnect power when opening an electric box.

CAUTION The vibration en route could have loosened one or more wire connections. Before connecting power, the electrician should check all screw connections in the control and junction boxes.

CAUTION The electrician must check rotation of all motors.

CAUTION Don't turn on the heaters until the tank is full. However, to avoid rust, don't fill the tank until you are ready for “start-up”.

1. SHIPPING DAMAGE: IF ANY DAMAGE IS FOUND, NOTIFY YOUR CARRIER IMMEDIATELY AND SAVE ALL CRATING MATERIALS FOR THE CARRIER'S INSPECTOR TO EXAMINE. FAILURE TO PROMPTLY REPORT DAMAGE COULD RESULT IN DENIAL OF YOUR CLAIM. A trucking companies procedure for handling damage claims is as follows:
 1. Immediately send out an inspector. An inspection report is filled out on the spot, a copy of which is given to the customer;
 2. The CUSTOMER has to call the carrier to request a claim form;
 3. The customer mails in the claim form and;
 4. The claim usually takes two (2) months to process.IF A UNIT IS SERIOUSLY DAMAGED, YOUR DEALER MAY BE ABLE TO INTERVENE, REQUESTING THAT THE DAMAGED UNIT BE RETURNED AND A NEW UNIT DELIVERED.

2. UNPACKING: To prevent shipping damage some parts may have been packed inside the machine.
 - Cut and remove any plastic ties connected to the turntable.

3. LOCATION: Consider the factors below when choosing a location:
 - If the unit is not vented with a blower, a considerable amount of steam will enter you plant. Make sure this steam will have no adverse affects in the surrounding area.

 - The process of removing wet parts from the machine will inevitably result in some water or solution spilling onto the floor. Consider traction mats around the machine and avoid placing the machine next to a walkway.

 - Allow room for your utility connections and for service. You will need 36" to unscrew the heating elements.

 - Make sure the site is level.

4. **ELECTRICAL HOOK-UP**: The voltage, phase, and amperage draw of the machine are listed on the serial number plate. The wiring diagram is either with this manual or inside the control box (make sure the amperage draws listed on the wiring diagram and serial number plate coincide). After the electrician connects power, he should check rotation of all motors. Hopefully, the electrician can be present for “start-up” in case a problem arises.
5. **DRAIN CONNECTIONS**: The unit has a 2” NPT coupler for draining the tank.
6. **WATER AVAILABILITY**: Make sure that a water line is available so that you can add water to the tank on a daily basis.

III. CHEMICAL SELECTION

CAUTION Fountain Industries’ detergents are characterized as “generally safe” on all metals. This is not an absolute guarantee. If the parts are critical, it is the customer’s responsibility to perform any and all metallurgical tests.

CAUTION Fountain Industries does not warranty their product against rust. Rust will occur if the wrong detergent is used, if the start-up procedure is not followed, or if the machine is not used on a regular basis (should oil the inside).

Using the correct detergent is critical to the performance and longevity of your jet washer. The detergent must be formulated for a mild steel jet washer, meeting the following criteria:

1. The detergent must have rust inhibiting agents to protect the mild steel machine and your steel parts. Once rusting starts, it can be hard to stop.
2. The detergent should be strong enough to remove the contaminants, but not so strong that it attacks the metal substrate.

3. The detergent should only leave an acceptable amount of residue on the parts. For new parts in particular, you may need a detergent that is “free rinsing”.
4. To be used in a jet washer, the detergent needs to be “low foaming”.

To insure the satisfaction of our customers, Fountain Industries has developed its' own line of detergents and additives.

IV. START-UP PROCEDURE

CAUTION Do not start this procedure until you have read this manual in its' entirety.

CAUTION Do not fill the tank or start this procedure unless you can spend the 3-4 hours necessary to heat the water, add detergent, and run the wash cycle for at least 2 hours. Otherwise, rusting may occur.

CAUTION Before turning on the electrical power, make sure the heat switch and wash timer are off. If the heating elements go on when the tank is empty, they will promptly burn out.

When using your jet washer for the first time, follow the steps below:

1. Make sure the electrical power to the machine is off.
2. Verify that your electrician checked the rotation of all motors.
3. Make sure the heat switch and wash timer is off.
4. Fill the wash tack so that the water depth is 11” (1” below the top edge of the filter basket.)
5. Turn on electrical power to the machine.
6. Set the thermostat between 150°-180°F (see “CONTROLS/OPERATION”)

7. Turn on the heating element by turning the heater toggle switch on.

Allow 1 1/2 hours for the water temperature to reach 150°F.

8. Turn on the oil skimmer using the on/off switch.
9. When the water temperature has reached at least 140°F, add detergent following the detergent manufacturers directions.

You can determine the water temperature by dialing the thermostat knob backward until you hear the heat contactor “clunk” open to shut-off the heating elements.

You can pour the detergent directly in the tank, or you can simply pour it on the floor beneath the turntable.

In the future, you may want to increase or decrease the detergent concentration depending on the cleaning results.

10. Close the door and run a 15 minute wash cycle to mix the detergent in solution.
11. During the wash cycle, walk around the machine checking for any leaks. Make sure the turntable drive motor is working.
12. At this point, you have checked every aspect of your machine. To thoroughly coat the inside of your machine with the rust inhibiting agents in the detergent, run at least two (2) hours worth of wash cycles at this time and for each of the next two (2) days. The more wash time you run, the more the cabinet gets coated with rust inhibitors.

IF YOU ENCOUNTERED ANY PROBLEMS DURING START-UP, CALL YOUR SPRAYMASTER DEALER.

V. MAINTENANCE

Assign the responsibility for your jet washer to one person to avoid abuse and neglect.

DAILY

1. Check the water depth which should be 11" (1" below the top edge of the filter basket);
2. Clean any spray holes that are clogged.
3. If any solution spilled onto the painted surfaces, wipe it off with fresh water.
4. Clean out the removable filter basket.

WEEKLY

1. Clean the oil skimmer, removing any build-up from the wiper blades and drainage canals.
2. Check your sludge clean-out schedule and remove the sludge if necessary.

TANK CLEAN-OUT/SLUDGE REMOVAL

Given the many different types and sizes of businesses that use Spraymaster jet washers, it is not possible to recommend a time schedule for cleaning out your tank. For some businesses the tank needs to be cleaned at least once a week while others can go months before they need to clean out the tank.

Obviously, the clean out schedule will be based on your cleaning volume, and on the amount of contamination on your parts. To prolong the clean out schedule in dirty rebuilding type applications, it often makes sense to scrape off caked on grease, dirt, etc... before putting the parts in the jet washer.

The tank should be cleaned out after the tank has accumulated more than 1" of sludge. Clean the tank after the first week of operation to determine what your clean out schedule should be.

To remove the sludge, follow these steps:

1. Disconnect power to the machine or make sure the pump and heat circuits are off.
2. While the turntable does not have to be removed, the tank area is more accessible when the turntable is taken out. To remove the turntable, back the

<u>SYMPTOM</u>	<u>REMEDY</u>
Nothing works-Heat or Pump	1. Breaker is off 2. Check all fuses
Cleaning is Poor	1. Wrong Detergent or low concentration 2. Clogged Nozzles 3. Solution is too dirty 4. Turntable is not rotating (see below) 5. Solution is not hot (see below) 6. Low output from pump (see below) 7. Nozzle pattern needs adjustment consult factory
Solution won't heat	1. Contactors pull in and voltage too heaters? one or more heating elements are bad 2. Contactor pulls in but <u>NO</u> voltage to heaters? Bad contactor 3. Contactor does not pull in? Replace contactor 4. Contactor does not pull in and <u>NO</u> voltage? Heater timer switch is bad or bad connection
Turntable not rotating	1. Gear motor wheel is worn 2. Turntable jammed or tilted 3. Check adjustment screw on gear motor
Pump motor on, but not pumping to capacity	1. Water level is too low 2. Pump is rotating backwards 3. Pump is broken 4. Solution is foaming 5. Spray nozzles are clogged 6. Solution is too hot 7. Something caught in pump
Pump and Gear motor failing	1. Defective Motor starter

2. Defective Pump timer

3. Defective door limit switch

Solution is foaming

1. Wrong Detergent

2. Solution is cold

3. Low concentration

4. Water level is too low

5. Add Defoamer

Cabinet is rusting

1. Wrong detergent. Use rust inhibitor

2. Machine is used too infrequently, not allowing cabinet to be coated with inhibitor

Oil skimmer not working

1. Switch is defective

2. skimmer motor defective

3. Wiper blades too tight against disc

SM 9400 REPLACEMENT PARTS LIST

PUMP & MOTOR	02-11021
SKIMMER ASSEMBLY KIT	61530
SKIMMER, MOTOR ONLY	12-08424-04
DRIVE MOTOR	02-11020
60 MINUTE TIMER	12-11025
12 HOUR TIMER	12-11054
RELAYS	01206
TOGGLE SWITCHES	12-10331
INDICATOR LIGHTS	12-11453
HEATER	12-12034
THERMOSTAT	12-11049
RUBBER WHEEL	02-11194
FUSES	12-11042

CHEMICAL

KT745	DETERGENT	14-11826
KT710	DEFOAMER	193565
KT720	RUST IHIBITOR	193567

SM 9400 COMPONENTS

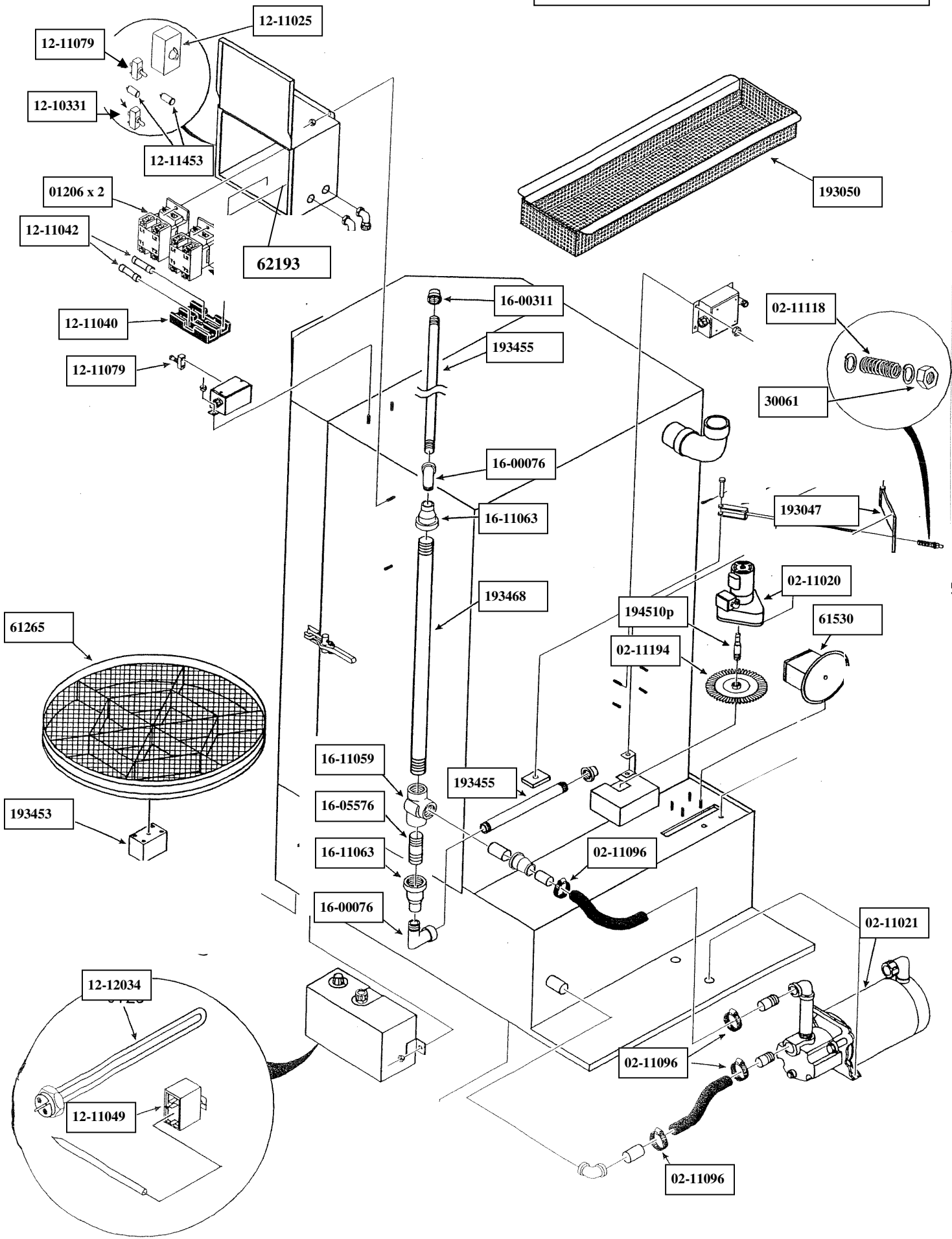

SM 9400 COMPONENTS

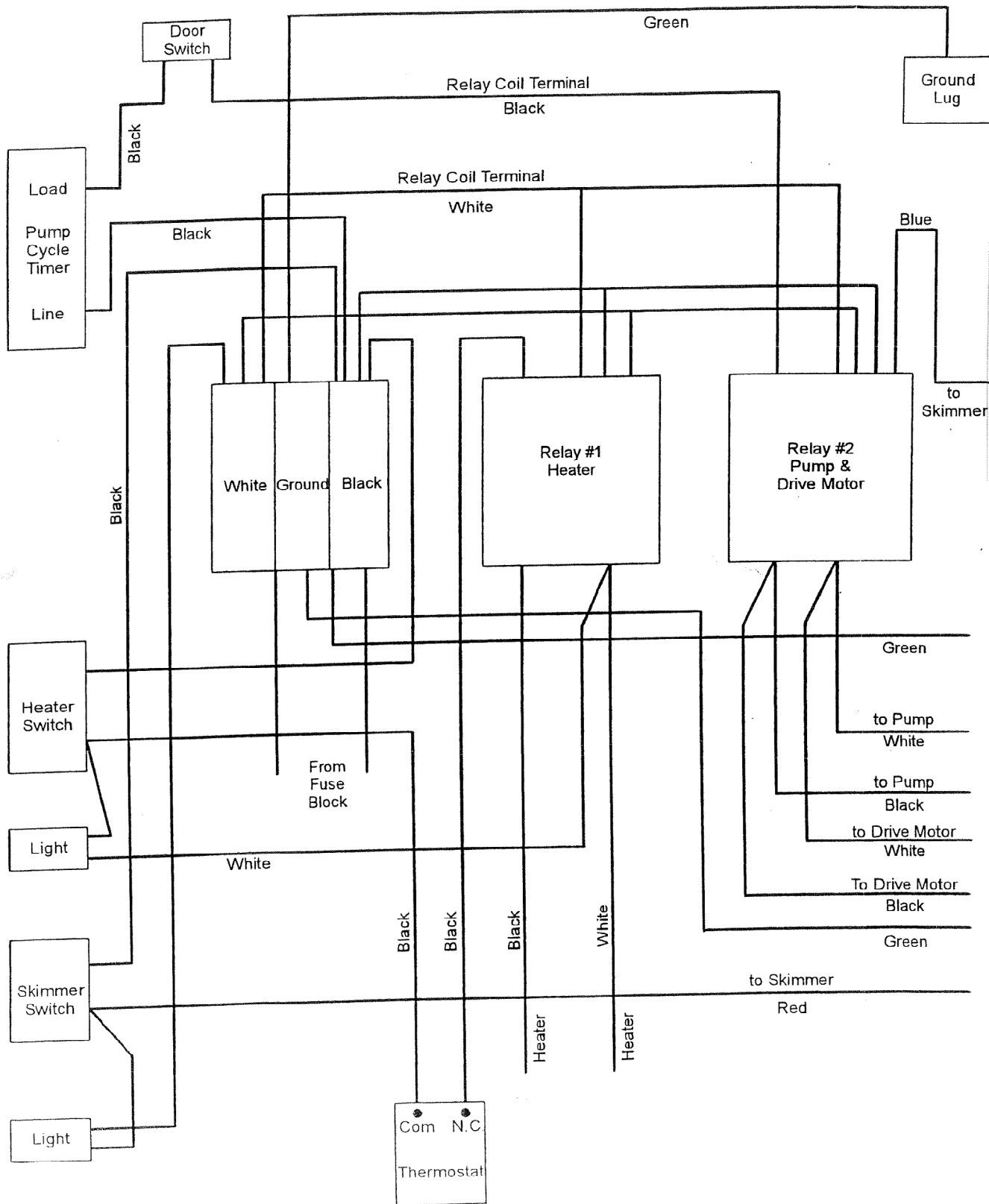

LIMITED WARRANTY AND LIMITATION OF REMEDIES AND DISCLAIMER. (1) Fountain Industries "Fountain" warrants the Equipment to be free from defects in material and manufacture and to conform to specifications for the Equipment at the time of shipment. This warranty is applicable only if the Equipment is installed, operated and maintained in accordance with factory recommendations and procedures. If any Equipment fails to conform to the specifications or samples or any defect in material or manufacture appears within twelve (12) months from the date of initial purchase by end user Fountain's entire liability, and Customer's exclusive remedy, shall be, to either repair or replace such defective Equipment, at Fountain's option, within a reasonable time after written notification thereof and return of the defective Equipment to Fountain.

(2) THIS WARRANTY IS MADE IN LIEU OF ALL OTHER WARRANTIES, EXPRESS OR IMPLIED, INCLUDING, BUT NOT LIMITED TO, THE IMPLIED WARRANTY OF MERCHANTABILITY, THE IMPLIED WARRANTY OF FITNESS FOR A PARTICULAR PURPOSE, ANY IMPLIED WARRANTY ARISING OUT OF COURSE OF DEALING OR OF PERFORMANCE, CUSTOM OR USAGE OF TRADE EXCEPT OF TITLE AND AGAINST PATENT INFRINGEMENT.

(3) LIMITATION OF LIABILITIES; TIME LIMIT FOR FILING ACTION. NEITHER PARTY SHALL UNDER ANY CIRCUMSTANCES BE LIABLE TO EACH OTHER FOR DAMAGES OF ANY KIND, INCLUDING, WITHOUT LIMITATION, DIRECT, INDIRECT, INCIDENTAL, SPECIAL OR CONSEQUENTIAL DAMAGES (INCLUDING, BUT NOT LIMITED TO, LOSS OF PROFITS, REVENUE OR BUSINESS) RESULTING FROM OR IN ANY WAY RELATED TO THE EQUIPMENT, ANY OF CUSTOMER'S PURCHASE ORDERS, THESE TERMS AND CONDITIONS OR THE TERMINATION OR NONRENEWAL THEREOF.

FOUNTAIN'S LIABILITY ON ANY CLAIM OF ANY KIND (INCLUDING NEGLIGENCE) FOR ANY LOSS OR DAMAGE ARISING OUT OF OR RESULTING FROM THIS AGREEMENT, OR FROM THE PERFORMANCE OR BREACH THEREOF, OR FROM THE EQUIPMENT FURNISHED HEREUNDER SHALL IN NO CASE EXCEED THE PRICE OF THE SPECIFIC EQUIPMENT WHICH GIVES RISE TO THE CLAIM. ALL SUCH LIABILITY SHALL TERMINATE UPON THE EXPIRATION OF THE WARRANTY PERIOD AS STATED HEREIN.

This limitation applies regardless of whether such damages are sought based on breach of contract, negligence, strict liability in tort or any other legal theory.

(4) Any action for breach of warranty or any other obligation under these Terms and Conditions must be commenced within one year from the purported date of breach.

(5) Each limitation on liability or remedy set forth in these Terms and Conditions is independent of any other limitation or if they are otherwise held to be unenforceable, that shall not affect the validity of any other such limitation or remedy.

Fountain assumes no liability for any claims for injury or damages to persons or property arising from any chemical manufactured by Customers or by third party vendors for use in Fountain's equipment.

Terms or conditions contained in any Customer purchase order or similar document that in any manner purport to alter, modify, change, or suspend these terms shall be deemed excluded from such purchase order and waived by the Customer.

This limited warranty does not cover or include consumable/wearable associated with such equipment.

Fountain assumes no liability for any unauthorized modifications carried out to the equipment not strictly recommended by the factory procedures.

This limited warranty is not transferable, and does not cover general equipment maintenance, demonstration, installation, routine servicing, calibration or customization of the equipment.

No person is authorized to alter or extend this limited warranty unless made in writing and signed by an authorized officer of Fountain.



Fountain Industries LLC
922 East 14th St.
Albert Lea, MN 56007

Tel: 800-328-3594
507-373-2351
Fax: 507-373-7404

Email: CS@FTNLLC.COM
Website: WWW.FOUNTAININDUSTRIES.COM